

**01-23 SERIES**

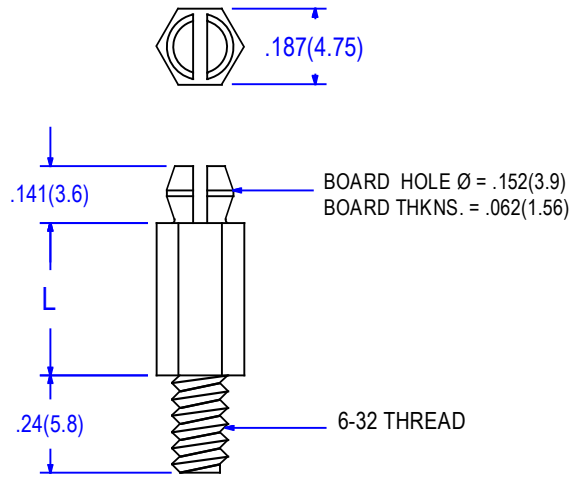

ITEM NO.	L	
	In. ±.015	mm. ± 0.4
01 - 23 - 20	.125	3.2
01 - 23 - 30	.187	4.8
01 - 23 - 40	.250	6.4
01 - 23 - 60	.375	9.5
01 - 23 - 80	.500	12.7
01 - 23 - 100	.625	15.9
01 - 23 - 120	.750	19.1
01 - 23 - 140	.875	22.2

PACKAGING : 1000 PER BAG

MATERIAL	NYLON 66
UL RATING	94V-2
UL FILE NO.	E41938
COLOR	NATURAL
RoHS COMPLIANCE	YES
TEMPERATURE RANGE (REF.)	-40 to 185°F (-40 to 85°C)
MR NUMBER	12

UL 94V-0 MATERIAL AVAILLE UPON REQUEST  
TO ORDER ADD SUFFIX "X" TO ITEM NUMBER

				BY	DATE	Title <b>PCB SUPPORT, STUD MOUNT.</b>	
				CUSTOMER			
				VERIFIED			
				REVIEWED			Part No.
				DRAWN	FL	10/20/20	<b>See Table</b>
				DIMES. Inches (mm) Tolerance (unless noted) .xx = ±.010 .xxx = .005			Issue <b>0</b>
				<b>ALL ELECTRONICS HARDWARE INC.</b> 2642 CORPORATE PARKWAY ALGONQUIN, ILLINOIS . 60102 1-800-778-7234			Drwg. type CATALOG
							File No. <b>01-23SERIES</b>
No	Revision	Date	Init.				10/20/20